

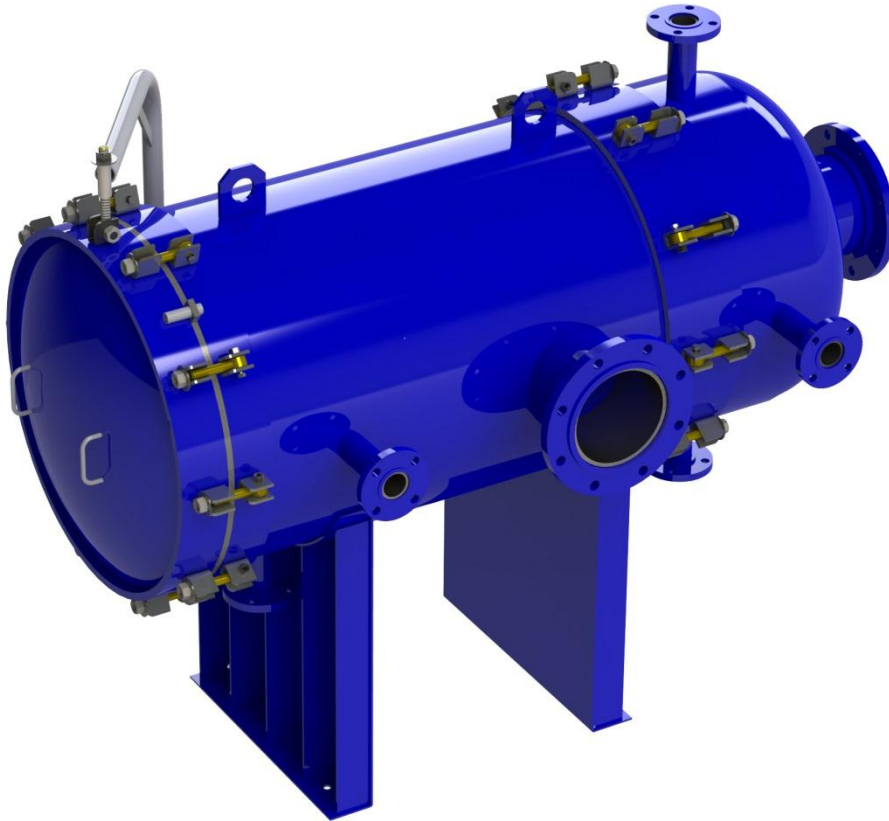

Fil-Trek

LH SERIES

Lined Cartridge Filter Housing
Horizontal Design
ASME Design
Universal



Water



Desalination



Chemicals



Electronics



Oil/Gas



Air/Gas



Inks/Paints/ Coatings



Power



Coolants



Pulp & Paper

LH SERIES

Horizontal

Lined Cartridge Filter Housings

- Multi-purpose, horizontal, industrial ASME "U" & "UM" code housings.
- Excellent for sea water or other corrosive applications.
- Accepts multiple 30", 40" & 50" cartridges.
- 150psig (10.3bar) @ 250°F(121.1°C) design pressure.
- Vessels available in carbon steel, with various lining options
- Cost effective solution in comparison to AL6XN or other duplex steels.
- Swing bolt closure allows for quick element change out.

For pricing or to order, please contact



204 North Link Lane #7
Fort Collins, CO 80524
Office 970-204-4758
Fax 970-204-4764

brandon@industrialfiltersource.com

LH SERIES

Lined Cartridge Filter Housing
Horizontal Design
ASME Design
Universal

Housing Specifications

Inlet/Outlet
3"-20" Flat Face Flange

Dirty Drain
2" Flat Face Flange

Clean Drain
2" Flat Face Flange

Vent
2" Flat Face Flange

Gauges
1/2" NPT

Certifications

U
UM
CE
NB
CRN

MODEL FLOW RATES

MODEL	# OF FILTERS	FLOW RATE (GPM)	MAX INLET/OUTLET	DESIGN
LH10	8	160	3"	Split
LH12	12	240	4"	Split
LH14	15	300	4"	Split
LH16	20	400	6"	Split
LH18	26	520	6"	Split
LH20	33	660	6"	Split
LH22	42	840	8"	Split
LH24	44	880	8"	Split
LH26	53	1,060	8"	Split
LH28	66	1,320	8"	Split
LH30	78	1,560	10"	Split
LH32	85	1,700	10"	Split
LH34	102	2,040	12"	Split
LH36	116	2,320	12"	Split
LH38	130	2,600	12"	Split
LH40	140	2,800	14"	Split
LH42	154	3,080	14"	Split
LH44	180	3,600	16"	Split
LH46	195	3,900	16"	Split
LH48	210	4,200	16"	Split
LH50	230	4,600	18"	Split
LH52	250	5,000	18"	Split
LH54	270	5,400	18"	Split
LH56	300	6,000	20"	Split
LH58	320	6,400	20"	Split
LH60	335	6,700	20"	Split

For maximum efficiency/product life, the flow rates are based on water at 5gpm/10". Actual Flow rate is dependent on fluid viscosity, cartridge micron rating, contaminant and type of media.

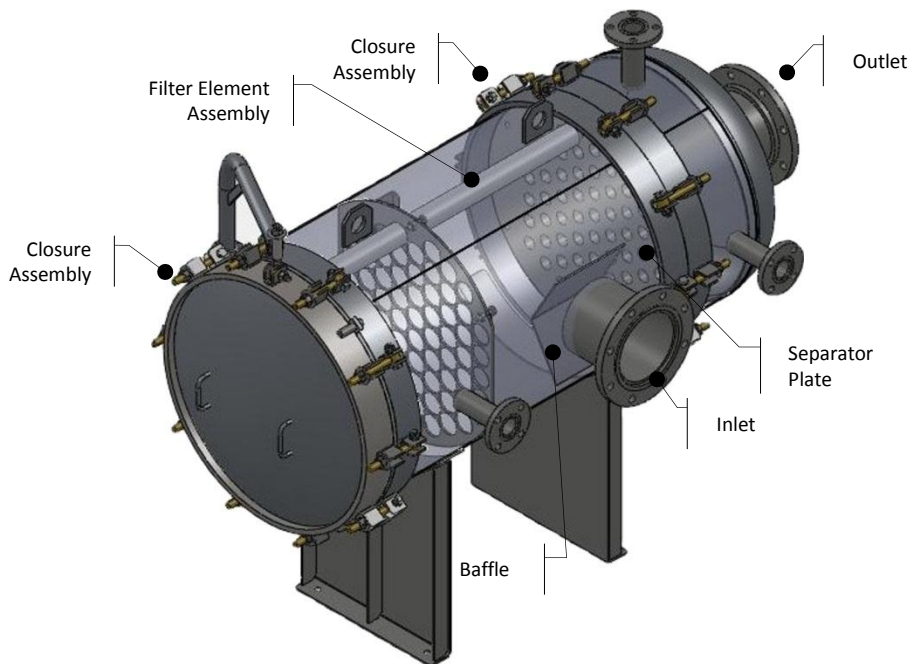

For pricing or to order, please contact



204 North Link Lane #7
Fort Collins, CO 80524
Office 970-204-4758
Fax 970-204-4764

brandon@industrialfiltersource.com

MATERIAL OF CONSTRUCTION	MAX. OPERATING PRESSURE (PSI @250°F)	MAX. DESIGN TEMP
CARBON STEEL	150 psi (10.3bar)	300°F (150°C)
304 STAINLESS STEEL	150 psi (10.3bar)	300°F (150°C)
316 STAINLESS STEEL	150 psi (10.3bar)	300°F (150°C)

MODEL DIMENSIONAL DETAILS

MODEL	SHIPPING WEIGHT (LBS)	A	B	C	D	E
LH10	300	10"	27"	15"	30"	88"
LH12	375	12"	30"	17"	30"	89"
LH14	525	14"	30"	17"	34"	90"
LH16	600	16"	32"	17"	34"	93"
LH18	700	18"	34"	18"	38"	94"
LH20	900	20"	36"	19"	40"	95"
LH22	1,000	22"	38"	20"	44"	98"
LH24	1,200	24"	40"	24"	50"	103"
LH26	1,350	26"	42"	26"	40"	104"
LH28	1,450	28"	42"	30"	40"	105"
LH30	1,500	30"	44"	30"	42"	105"
LH32	1,700	32"	46"	32"	44"	108"
LH34	1,800	34"	46"	32"	46"	108"
LH36	1,950	36"	48"	34"	48"	112"
LH38	2,100	38"	50"	34"	50"	116"
LH40	2,200	40"	54"	36"	52"	118"
LH42	2,500	42"	58"	38"	54"	119"
LH44	2,575	44"	60"	38"	56"	120"
LH46	2,650	46"	64"	38"	59"	120"
LH48	2,750	48"	66"	40"	62"	122"
LH50	3,000	50"	70"	42"	66"	126"
LH52	3,100	52"	74"	44"	66"	130"
LH54	3,150	54"	78"	46"	68"	133"
LH56	3,300	56"	72"	48"	68"	136"
LH58	3,400	58"	76"	50"	70"	138"
LH60	3,600	60"	80"	52"	72"	140"

*Above dimensions are for 40" Element, Style C. For other options contact factory. **Given dimensions are approximate only, for true dimensions contact factory.

REFERENCE CHART LEGEND

A	OUTSIDE DIAMETER
B	FLOOR TO INLET
C	FLOOR TO OUTLET
D	FACE TO FACE
E	OVERALL HEIGHT (SW/VB)

STYLE C

SPLIT-BODY

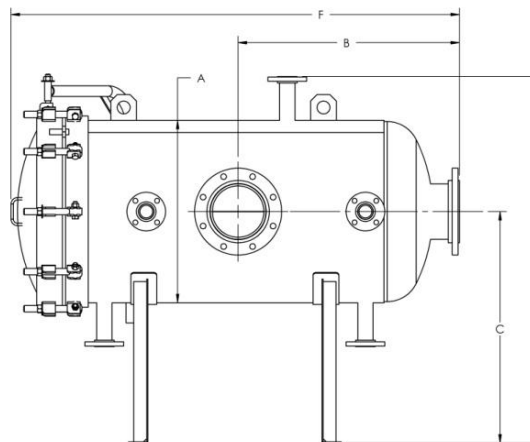

PRODUCT NOMENCLATURE

LH	18	29	4	6F	RL	A	-	-
MODEL	HOUSING DIAMETER	# OF CARTRIDGES	LENGTH	CONNECTION TYPE	LINING MATERIAL	CONFIGURATION	FILTER CONFIG	O-RING
LH ASME CODE	SEE TABLE	SEE TABLE	3 - 30	SEE TABLE	KY KYNAR	A SIDE IN/SIDE OUT	SEE SIDE PANEL FOR OPTIONS	
			4 - 40		RL RUBBER	C (STD) SIDE IN/BOTTOM OUT		
			5 - 50		TE TEFLON			
					NP NEOPRENE			
					PC PVC			
					BP BAKED PHENOLIC			
					EX EPOXY			
					HR HALAR			

Lined Cartridge Filter Housing
Horizontal Design
ASME Design
Universal

Configuration Options

A – Side in/side out
C – Side in/Bottom out (standard)

O-Ring Options

(-) – Buna-N (standard)
ED – EPDM
VI – Viton
SI – Silicone
TEV – Teflon encapsulated Viton
TF – Teflon

Head Lift Options

(-) – K1 – Head lift (standard)
K2 – Hinge
K3 – Hydraulic Jack Davit Side
K4 – Hydraulic Jack Davit Top

Accessories

Direct Reading Gauge
DP Gauge
Safety Relief Valves
Vent Valves
Drain Valves
Air Eliminator

Filter Configuration

E1 – Double Open End
E2 – DOE with Gasket Ends
E3 – DOE with 1" Ext. Core
E4 – SOE Flat End 222 Open End
E5 – SOE Fin End 222 Open End
E8 – SOE Plastic Spring Top 222
E9 – SOE Plastic Spring Top

For pricing or to order, please contact



204 North Link Lane #7
Fort Collins, CO 80524
Office 970-204-4758
Fax 970-204-4764

brandon@industrialfiltersource.com

LH SERIES

Lined Cartridge Filter Housing
Horizontal Design
ASME Design
Universal

FLOW CHART

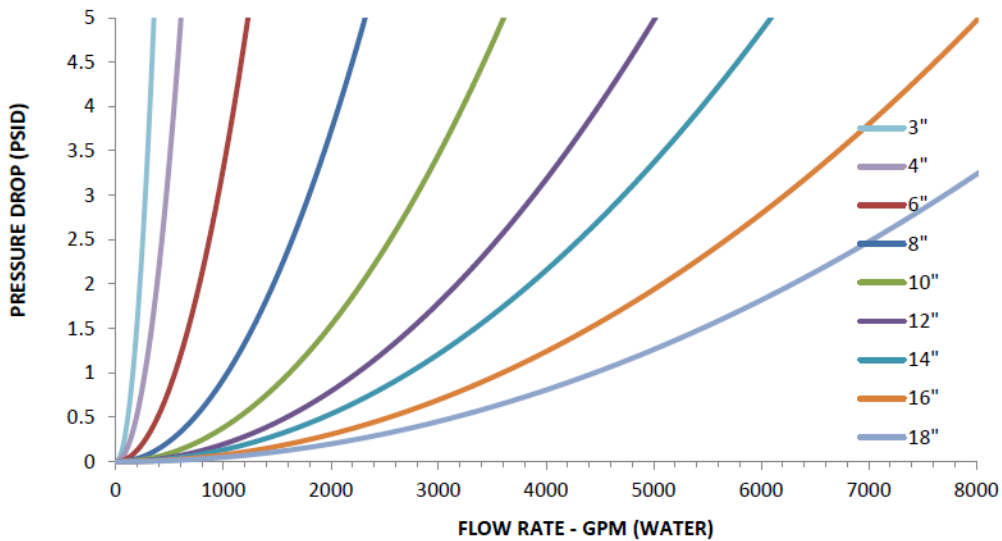

For pricing or to order, please contact



204 North Link Lane #7
Fort Collins, CO 80524
Office 970-204-4758
Fax 970-204-4764
brandon@industrialfiltersource.com